

# Installation Instructions | TriPlane Linear: Horizontal Driver Mount

**Always turn off and lock out the branch circuit before commencing installation or maintenance work.**

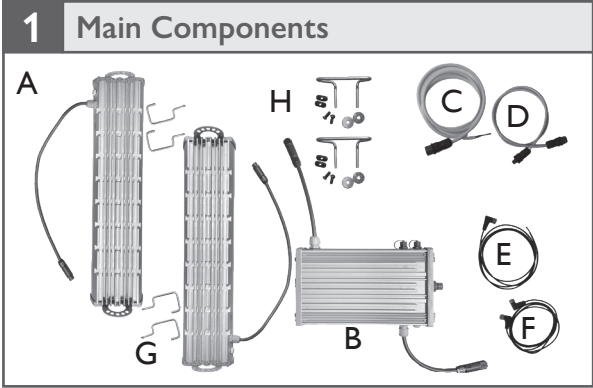

- Unbox luminaire(s) and place on soft surface, along with relevant accessories.
- A** LED Module(s)
  - B** Driver Module
  - C** Power Supply Cord
  - D** Daisy-Chain Power Connector Cord\*
  - E** 0-10V Control Supply Cord\*
  - F** Daisy-Chain 0-10V Dimming Connector Cord\*
  - G** LED Module Mounting Brackets (x4)
  - H** Driver Module Mounting Brackets w/Hardware (x2)

*optional accessories*

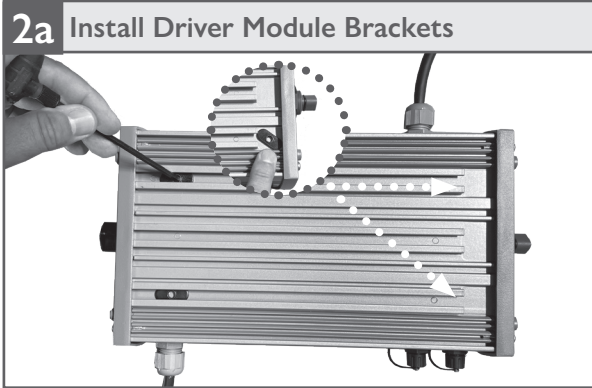

- Line a tab nut up with the top opening of each of the two outer channels on driver module housing.
- Slide tab nuts down the channels until they are aligned side-by-side on the opposite end of the driver module.

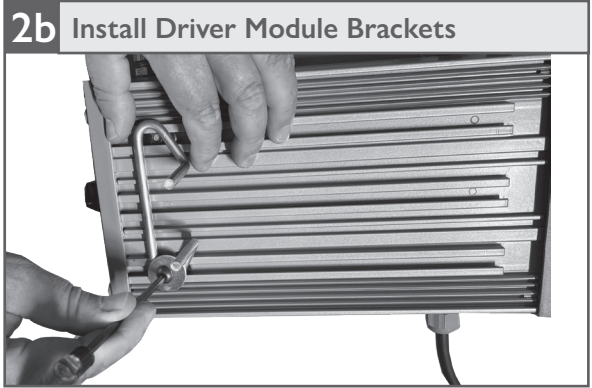

- Position mounting bracket with hooks facing towards the middle / inside of the driver module. Align the inside of the "elbow" bends with holes in tab nuts.
- Slide screw through hole in washer before placing over bracket & loosely threading into tab nut below.
- Tighten down screw & repeat to install 2nd screw.

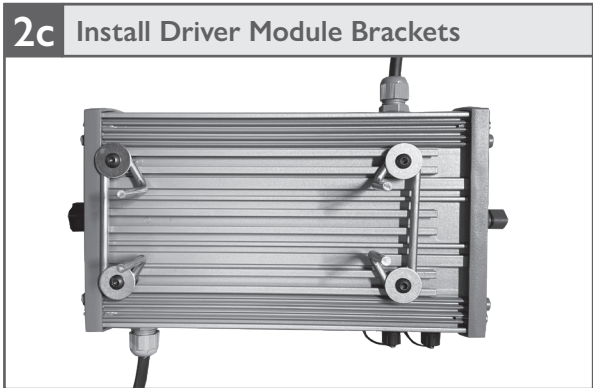

- Repeat steps 2a & 2b to install second driver mounting bracket on opposite end of driver module.
- Hooks should be facing towards each other.
- Ensure screws in both brackets are tightened down.

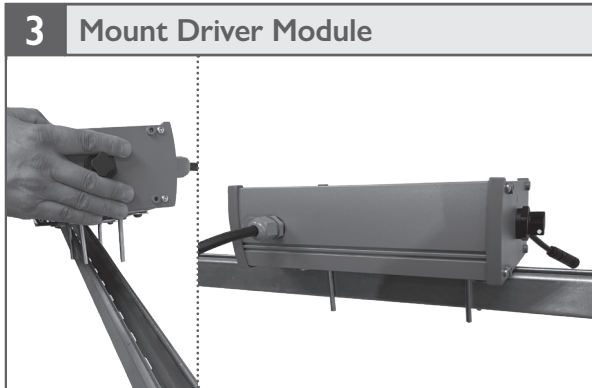

- Raise driver module to ceiling and lower mounting brackets over the track/truss, ensuring the driver module is securely in place.

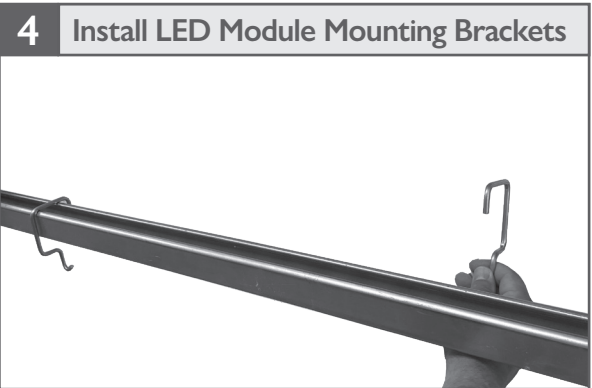

- Hook one LED module bracket over top of mounting structure in accordance with the LED module position indicated in your light plan.
- Position second mounting bracket 26 inches away from the first, with the hook facing in the opposite direction.
- Repeat with second set of mounting brackets on opposite side of driver module.

**! ATTENTION: Luminaires should only be installed by qualified individuals, and in accordance with national and local building and electrical codes. !**

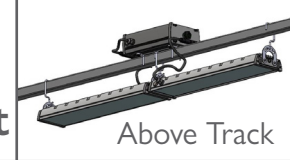

## 5a Mount LED Modules

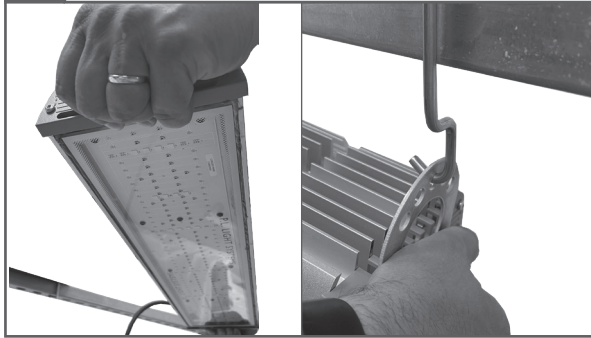

- Supporting from below on either end, raise the LED module towards mounting structure and insert open hook of installed mounting bracket through the desired hole in the LED module end bracket.

*NOTE: Avoid touching the glass lens (unless you are wearing clean cotton gloves), as this could leave grimy/oily deposits on the lens.*

## 5b Mount LED Modules



- Still supporting the opposite end, insert the open hook of the second installed mounting bracket through the corresponding hole in the LED mounting bracket so that LED module is fully supported.
- Repeat with second LED module.

## 6 Connect LED Modules

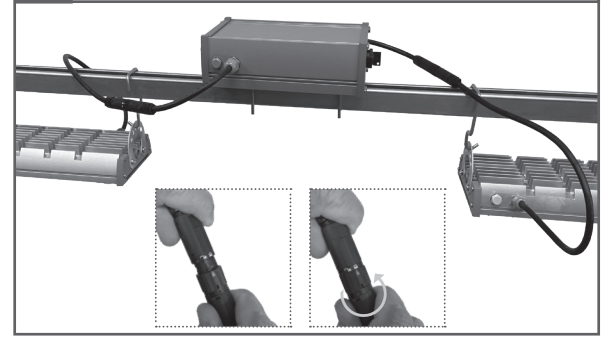

- Align open ends of connectors on driver module and LED module in the "unlocked" position.
- Push together and ensure the connector is in the "locked" position to complete the connection.
- Repeat to connect second LED module to driver module.

## TAKE NOTE

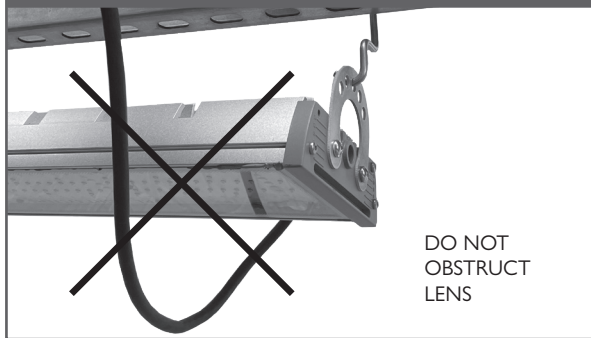

*NOTE: Never position cords beneath the LED module(s), as they will obstruct the light output and light uniformity on the crop. Cords should instead, be positioned so that they can be secured to the mounting structure above the LED module, with a drip loop to draw moisture away from the connector.*

## 7 Connect Power Cord

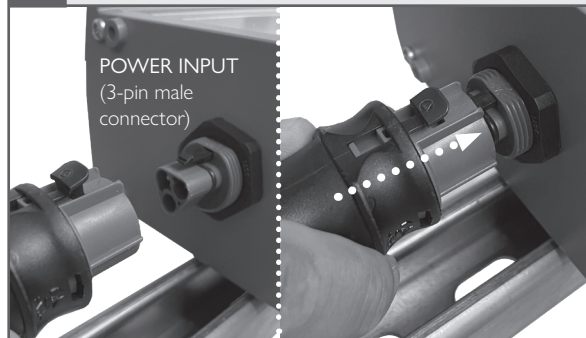

- Connect the whip end of the power cord to branch circuit. Align 3-pin female connector on power cord with 3-pin male input connector on luminaire and push into luminaire connector until firmly engaged.

*NOTE: Coil and secure excess cable - allowing for drip loops to draw moisture away from connectors*

## 8 Connector Cap

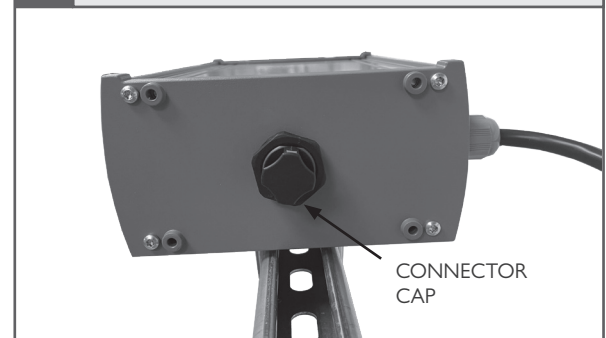

- Ensure that factory-installed connector cap remains firmly engaged in 3-pin female connector at opposite (power out) end of luminaire to ensure safe operation and IP integrity.
- Cap should ONLY be removed if luminaire is connected to another for daisy chaining.

*NOTE: Both connectors on the luminaire must be sealed (either with a power cord, daisy-chain connector cord or a cap) once installed. Use of luminaire(s) with exposed connectors will void the product warranty.*



**ATTENTION: Luminaires should only be installed by qualified individuals, and in accordance with national and local building and electrical codes.**





# Installation Instructions | TriPlane Linear: Horizontal Driver Mount

## 9 Connect to Control System

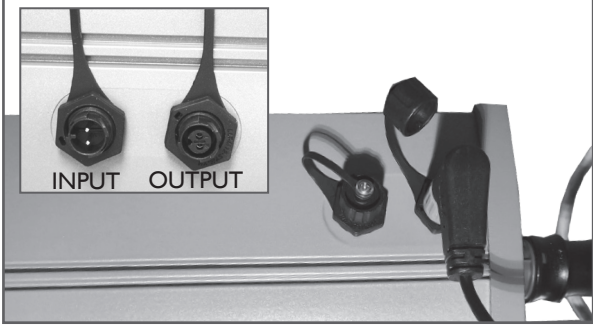

- If connecting luminaire(s) to a control system, remove connector cap from 0-10V input connector on luminaire.
- Push and click open end of right-angle female connector on 0-10V control supply cord into the male control input connector on luminaire and twist to lock.
- Secure whip end of 10V control supply cord to mounting structure, leaving enough slack to create drip loop.
- Connect whip end to control system.

*NOTE: Both 0-10V connectors on the luminaire must remain capped when not in use to ensure safe operation and IP integrity. Use of luminaire(s) with exposed connectors will void the product warranty.*

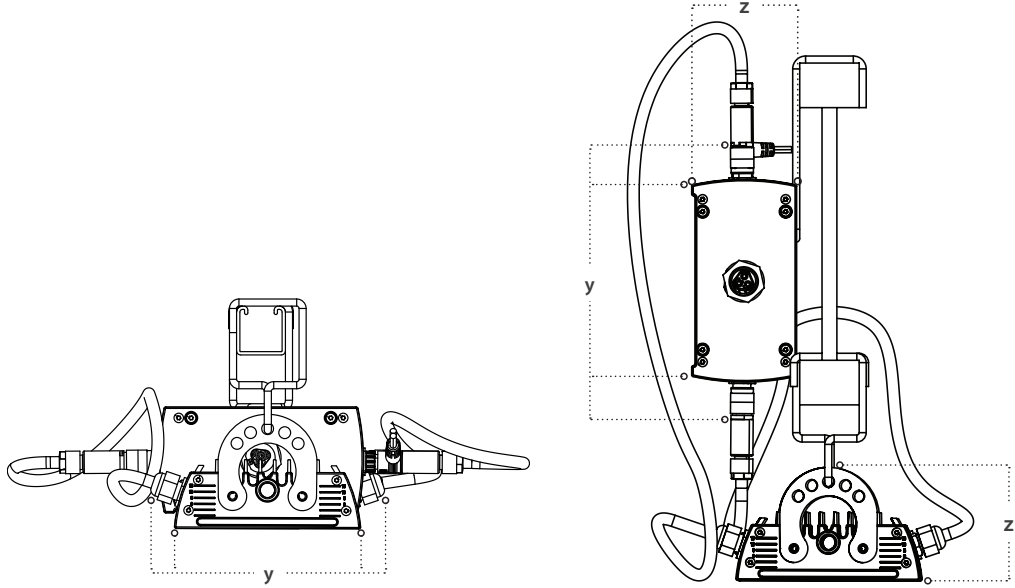

LUMINAIRE DIMENSIONS						
	LED Module		Driver Module (208-400V models)		Driver Module (480V models)	
	excl. connectors	incl. connectors	excl. connectors	incl. connectors	excl. connectors	incl. connectors
Length (x)	25.60 in (650mm)		13.30 in (338 mm)		25.20 in (640 mm)	
Width (y)	6.22 in (158 mm)	7.83 in (199 mm)	9.13 in (232 mm)	13.31 in (338 mm)	9.13 in (232 mm)	13.31 in (338 mm)
Height (z)	3.82 in (97mm)		3.55 in (90mm)		3.55 in (90mm)	
Weight	11.2 lb. (5.1 kg)		6.8 lb. (3.1 kg)		16.1 lb. (7.3 kg)	

**! ATTENTION: Luminaires should only be installed by qualified individuals, and in accordance with national and local building and electrical codes. !**



If you are daisy-chaining your luminaires, follow steps 1-10 above, then proceed as follows:

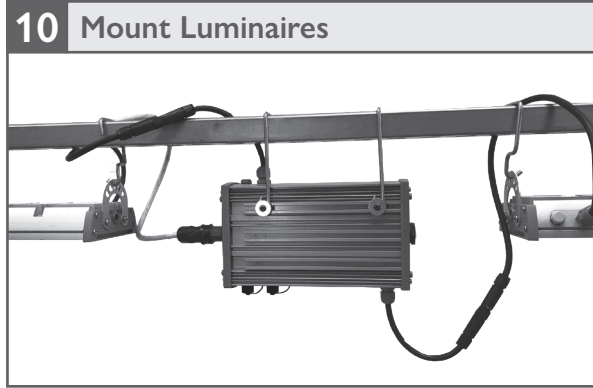

- Mount remaining luminaire(s) to be connected in daisy-chain string in accordance with light plan.

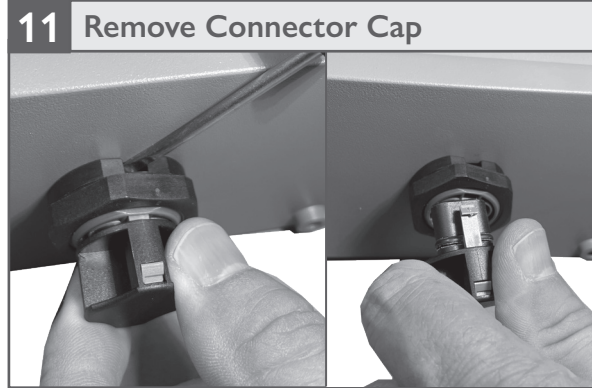

- Remove preinstalled connector cap in 3-pin connectors on "power out" side of luminaire(s) between adjacent modules in daisy-chain string.

*TIP: Store removed connector caps in safe place as they will need to be re-installed if daisy-chain connector is ever removed.*

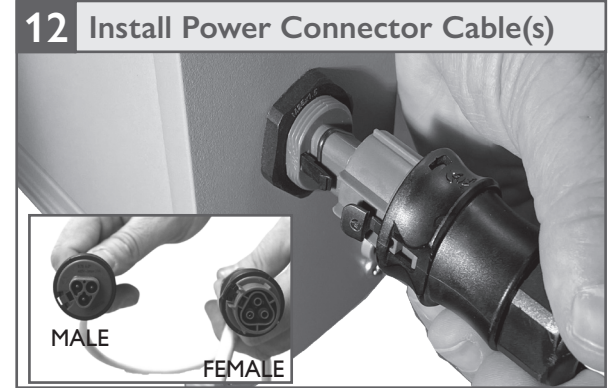

- Securely connect the modules with daisy-chain power connector cables (available in lengths of 3 ft / 6ft / 10 ft / 15ft). Daisy-chain connector cables have a 3-pin female connector on one end, and a 3-pin male connector on the other end.
- The 3-pin male connector on the cord must be installed into the corresponding 3-pin female "power out" connector on the luminaire. The 3-pin female connector must be installed into the corresponding 3-pin male "power in" connector on the next luminaire in the string.

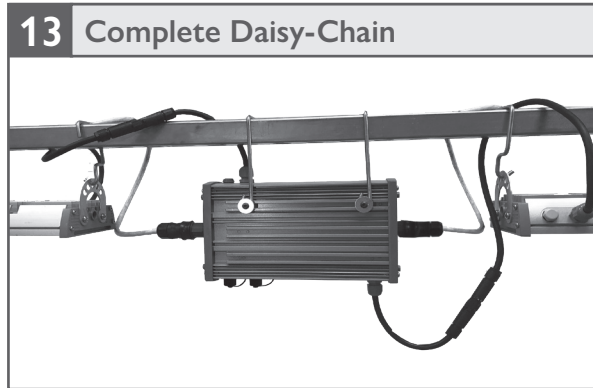

- Continue until daisy-chain is complete.
- Ensure the connector cap remains firmly installed in 3-pin "power out" connector of the last luminaire in daisy-chain string to ensure safe operation and IP66 integrity.
- Secure all cable(s) to mounting structure - allowing for drip loops.

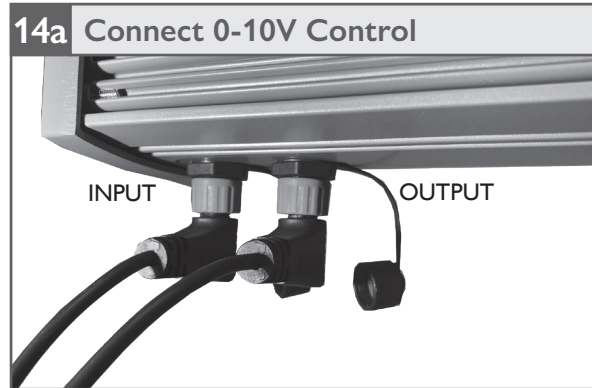

- If daisy-chaining 0-10V control, connect 1st luminaire in string to control system as previously described.
- Remove connector cap on female control output connector on luminaire and insert open end of right-angle male connector on 0-10V daisy-chain dimming cord (should click into place).



- Secure dimming cord along mounting structure and (after removing cap) insert open end of right-angle female connector on opposite end of cord into male control input connector on adjacent luminaire.
- Coil and secure excess cable - allowing for drip loops to draw moisture away from connectors.

**! ATTENTION: Luminaires should only be installed by qualified individuals, and in accordance with national and local building and electrical codes. !**



## 15 Complete Daisy-Chaining



- Continue until daisy-chain is complete.
- Ensure that connector cap remains firmly installed on 0-10V output connector of last luminaire in daisy chain string to ensure safe operation and IP66 integrity.

Refer to table below for maximum number of luminaires that can be daisy-chained per string, based on your voltage and luminaire output.

DAISY-CHAIN GUIDE		Max. Number of Luminaires / String	
		Luminaire Output	
		HO	LO
POWER	208V	3	6
	240V	4	7
	277V	4	8
	347V	5	10
	400V	6	12
	480V	6	12
DIMMING		25	25

## ATTENTION

- The TriPlane Linear dimming is a 0-10V sourcing supply (0.68mA/luminaire) that can be dimmed to off, however, for maximum energy savings P.L. Light Systems recommends using the control system to isolate the mains.
- Always ensure that cords are:
  - Coiled and excess cable secured - allowing for drip loops to draw moisture away from connectors.
  - Not concealed or extended through a wall, floor, ceiling, or other parts of the building structure
  - Not located above a suspended ceiling or dropped ceiling,
  - Not permanently affixed to the building structure
  - Not routed so that they are not subject to strain and are protected from physical damage
  - Visible over their entire length
  - Used within their rated ampacity as determined for the maximum temperature of the installed environment specified in the instructions

### PHOTOBIOLOGICAL RISK GROUP 2

**CAUTION** Possibly hazardous radiation emitted from this product. Do not stare at operating lamp. May be harmful to the eyes.

Product tested against IEC 62471

*Photobiological risk is based on testing of the light output characteristic of a single luminaire. Increased exposure risk to facility personnel may be present, depending on number of luminaires and their placement and/or positioning within the facility. It is the responsibility of the facility management to address these risks at the facility level and to ensure that people entering the plant growth areas while the lights are on, are aware of these risks and that appropriate safeguards are in place.*



**ATTENTION:** Luminaires should only be installed by qualified individuals, and in accordance with national and local building and electrical codes.

